

# Installation Instructions For Natural Gas Conversion (Kit Part No. 1173865)

This kit is designed for conversion to Natural Gas.

Table 1	Natural Gas Orifice Kits and Sizes								
	Elevation Above Sea Level								
	0 to 2000 ft		2001 to 4000 ft	4001 to 5000 ft	5001 to 6000 ft	6001 to 7000 ft	7001 to 8000 ft	8001 to 9000 ft	9001 to 10000 ft
Model Number	Orifice Drill #	Kit Number	Orifice Drill # (Field-Supplied)	Orifice Drill # (Field-Supplied)	Orifice Drill # (Field-Supplied)	Orifice Drill # (Field-Supplied)	Orifice Drill # (Field-Supplied)	Orifice Drill # (Field-Supplied)	Orifice Drill # (Field-Supplied)
PGAA, PGMD (All Sizes)	44	1173863	45	46	47	47	48	48	49
PGAD, PGME (All Sizes)	44	1173863	45	46	47	47	48	48	49
PGX3, PDX3 (All Sizes)	44	1173863	45	46	47	47	48	48	49
PGC***K040F, GPCM**K040	44	1173863	45	46	47	47	48	48	49
PGC***K060F, GPCM**K060	44	1173863	45	46	47	47	48	48	49
PGC***K080F, GPCM**K080	44	1173863	45	46	47	47	48	48	49
PGC***K100F, GPCM**K100	41	1173865	43	43	43	44	44	45	46
PGC***K120F, GPCM**K120	42	1173865	43	43	44	44	45	46	47
PGC***K140F, GPCM**K140	42	1173865	43	43	44	44	45	46	47
PGF***K040F, GPFM**K040	44	1173863	45	46	47	47	48	48	49
PGF***K060F, GPFM**K060	44	1173863	45	46	47	47	48	48	49
PGF***K080F, GPFM**K080	44	1173863	45	46	47	47	48	48	49
PGF***K100F, GPFM**K100	41	1173865	43	43	43	44	44	45	46
PGF***K120F, GPFM**K120	42	1173865	43	43	44	44	45	46	47
PGF***K140F, GPFM**K140	42	1173865	43	43	44	44	45	46	47
PGS***K040F, GPSM**K040	44	1173863	45	46	47	47	48	48	49
PGS***K060F, GPSM**K060	44	1173863	45	46	47	47	48	48	49
PGS***K080F, GPSM**K080	44	1173863	45	46	47	47	48	48	49
PGS***K100F, GPSM**K100	41	1173865	43	43	43	44	44	45	46
PGS***K120F, GPSM**K120	42	1173865	43	43	44	44	45	46	47
PGS***K140F, GPSM**K140	42	1173865	43	43	44	44	45	46	47
PGF3**040	44	1173863	45	46	47	47	48	48	49
PGF3**060	44	1173863	45	46	47	47	48	48	49
PGF3**080	44	1173863	45	46	47	47	48	48	49
PGF3**100	41	1173865	43	43	43	44	44	45	46
PGF3**120	42	1173865	43	43	44	44	45	46	47
PGF3**140	42	1173865	43	43	44	44	45	46	47

Note: \*\*\* or \*\*\*\* may be any combination of numbers and/or letters in the model number.

Note: The orifice sizes in the chart above derate the input rate at 4% per 1000 feet above sea level for altitudes exceeding 2000 feet above sea level.

Natural gas data is based on .60 specific gravity, a heating value of 1030 Btu/cubic foot, and 3.5 "W.C. manifold pressure.

For fuels with different specific gravity and/or different heating values, consult the National Fuel Gas Code ANSI Z223.1 - 2002/NFPA 54-2002 or

National Standard of Canada, Natural Gas and Propane Installation Code CSA B149.1-00.

Note: If converting from LP gas to Natural gas at altitudes exceeding 2000 feet above sea level, conversion kit (Part #330732-401) is required for proper conversion. For all models, except PGX3, PDX3, and PGF3, a .018 pilot orifice (Part # 5032110) is also required.

## Parts List, Kit # 1173865

Description	Part #	Qty
<b>Burner Orifice #41</b>	<b>1096942</b>	<b>7</b>
<b>Burner Orifice #42</b>	<b>1011351</b>	<b>7</b>
<b>Pilot Orifice (0.018)</b>	<b>503211</b>	<b>1</b>
<b>Honeywell Conv. Kit #396222</b>	<b>1172952</b>	<b>1</b>
<b>Label, Natural Gas Conversion</b>	<b>1173866</b>	<b>1</b>
<b>Label, Field Conversion</b>	<b>1009678</b>	<b>1</b>
<b>Instructions</b>	<b>462 06 1211 00</b>	<b>1</b>

## SAFETY REQUIREMENTS

Recognize safety information. This is the safety-alert symbol . When you see this symbol in instruction manuals be alert to the potential for personal injury.

Understand the signal words DANGER, WARNING, or CAUTION. These words are used with the safety-alert symbol. DANGER identifies the most serious hazards, those that will result in severe personal injury or death. WARNING signifies a hazard that could result in personal injury or death. CAUTION is used to identify unsafe practices that may result in minor personal injury or product and property damage. NOTE is used to highlight suggestions that will result in enhanced installation, reliability, or operation.

Installing and servicing heating equipment can be hazardous due to gas and electrical components. Only trained and qualified personnel should install, repair, or service heating equipment. Untrained service personnel can perform basic maintenance functions such as cleaning and replacing air filters. All other operations must be performed by trained service personnel. When working on heating equipment, observe precautions in the literature, on tags, and on labels attached to or shipped with the appliance and other safety precautions that may apply.

Follow all safety codes. In the United States, follow all safety codes including the National Fuel Gas Code (NFPA) ANSI Z223.1-2006/NFPA 54-2006. In Canada, refer to the of the National Standard of Canada Natural Gas and Propane Installation Code (NSCNGPIC) CSA B149.1-05. Wear safety glasses and work gloves. Have fire extinguisher available during start-up and adjustment procedures and service calls.

These instructions cover minimum requirements and conform to existing national standards and safety codes. In some instances, these instructions exceed certain local codes and ordinances, especially those that may not have kept up with changing residential construction practices. We require these instructions as a minimum for a safe installation.

## Important Information

This kit includes a Honeywell conversion kit for converting Honeywell VR8200, VR8205S, SV9500, SV9501 or VR8204M gas valves certified for use with Propane Gas (and so marked) to units functionally the same as the certified furnace for use with Natural Gas. If converting from propane gas to natural gas, the gas valve conversion kit, main burner orifices, and pilot orifice, all found in this kit, must be installed.

For converting the furnace from standard altitude on natural gas to high altitude (2001 feet above sea level or greater) on natural gas, the Honeywell conversion kit and pilot orifice changes are not needed. Only the main burner orifices require changing. Refer to **Table 1** for proper orifice size for specific model number, input capacity, and installation altitude.

The orifices provided in this kit are stamped to indicate the size (twist drill number) and are sized for natural gas ONLY. Do NOT use them with butane or a mixture of butane and propane. The parts list specifies the size orifices supplied in the kit. Compare the size marking on the orifices with the sizes as listed in the parts list. Make sure you have the correct main burner orifices.

Extreme care is used to assure that this kit contains the proper orifices. **Oversized orifices could result in hazardous conditions, especially if the venting is inadequate.** For that reason, we recommend that the installer check the size of the orifice with a new twist drill of the correct size. This procedure assures that the orifices provided are the correct size.

- Fill out and attach the Field Conversion Label to the front exterior of the furnace.

### **⚠ WARNING**

**FIRE, EXPLOSION, CARBON MONOXIDE POISONING HAZARD.**

**Failure to follow these instructions exactly could result in personal injury, death and/or property damage.**

**This conversion kit shall be installed by a qualified service agency in accordance with the manufacturer's instructions and all applicable codes and requirements of the authority having jurisdiction. If the information in these instructions is not followed exactly, a fire, an explosion or production of carbon monoxide may result causing property damage, personal injury or loss of life. The qualified service agency is responsible for the proper installation of this kit. The installation is not proper and complete until the operation of the converted appliance is checked as specified in the manufacturer's instructions supplied with the kit.**

## Gas Pressure

- Refer to the furnace rating plate for the approved gas input rating.
- Gas input to burners MUST NOT exceed the rated input shown on rating plate.
- **Do NOT** allow minimum gas supply pressure to vary downward. Doing so will decrease input to furnace. Refer to **Table 2** for gas supply and manifold pressures.

Table 2		Gas Pressures		
Gas Type	Supply Pressure			Manifold Pressure
	Recommended	Max.	Min.	
Natural	7"	13"	4.5"	3.5"

## Installation

### **⚠ WARNING**

**ELECTRIC SHOCK HAZARD/FIRE AND/OR EXPLOSION HAZARD.**

**Failure to follow this warning could result in property damage, equipment damage, personal injury and/or death.**

**Turn OFF gas supply at manual gas valve before turning OFF electric power supply and starting installation.**

**Turn OFF electric power supply at disconnect switch or service panel before starting installation.**

- Shut off gas supply to furnace at manual shut-off valve before starting installation.

### **⚠ WARNING**

#### **EXPLOSION HAZARD**

**Failure to follow this warning could result in personal injury, death and/or property damage.**

**If unit is still running, allow 2.5 minutes after gas shut off before turning off power, Shut Off electric power at unit disconnect and service panel.**

- Disconnect electric power supply to the furnace before starting installation.
- Check for gas leaks after installation of kit and before attempting to start furnace.
- Locate the Natural Gas Conversion Label next to the furnace rating plate.

## Disassembly

Refer to **Figure 1** and the following steps.

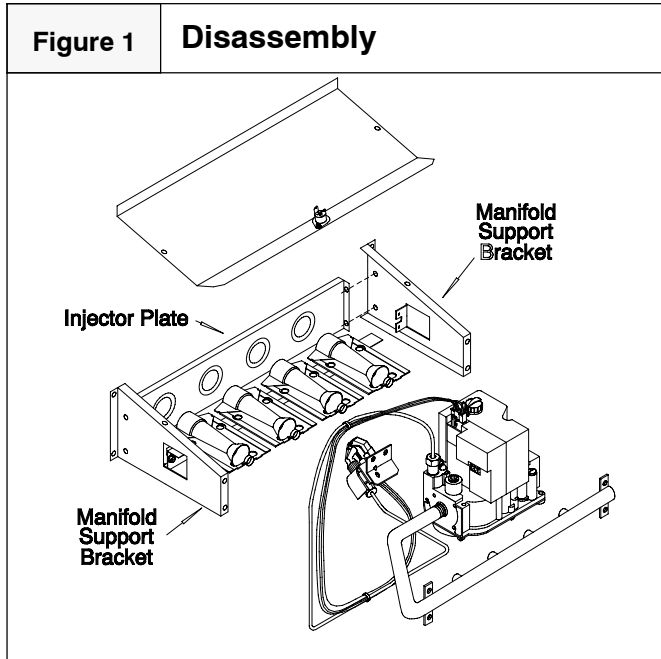

1. After shutting off gas supply and electric power to the unit remove the access door, exposing gas valve and burner compartment.
2. Disconnect gas line from gas valve so manifold assembly can be removed.
3. Disconnect wiring at gas valve. Be sure to note the proper location of any and all electrical wiring disconnected.
4. If converting from Propane Gas to Natural Gas, remove the pilot supply line from the gas valve.
5. Remove the four (4) screws holding the manifold and gas valve to the manifold supports. Do Not discard any screws.
6. Carefully remove the manifold assembly.
7. If converting from Propane Gas to Natural Gas in the state of California, NOx baffles must be installed to comply with California law. NOx baffles can be ordered from Fast Parts. Remove the two (2) screws holding the burner assembly in place. Install the correct NOx baffle for the unit, if required, and replace the Burner Assembly using the original two screws, **Figure 2**.

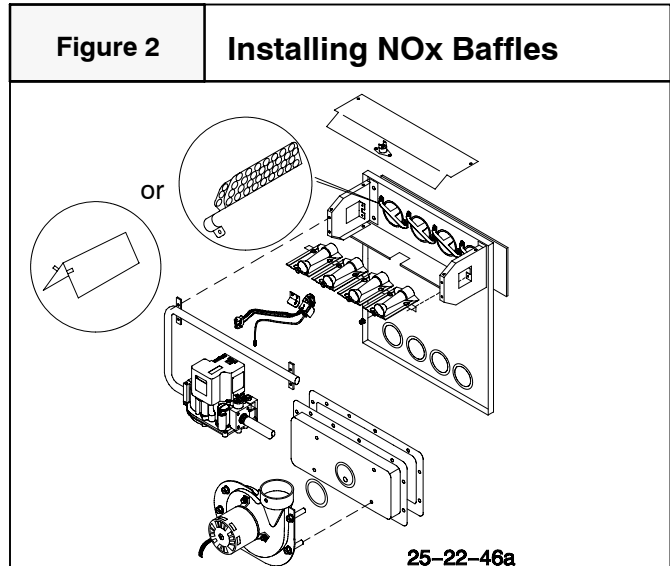

## Changing Main Burner Orifices

1. Remove the gas burner orifices from the manifold assembly using a box end wrench or socket wrench, **figure 3**, and replace them with the proper orifice size for the specific furnace model, input size, and altitude from **table 1**.

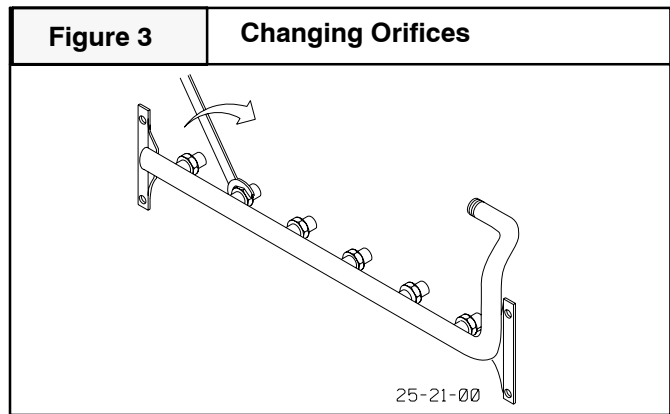

2. Tighten the orifices so they are  $1\frac{3}{16}$ " from the face of the orifice to the backside of the manifold (**See Figure 4**). Make sure orifice is installed straight so that it forms a right angle ( $90^\circ$ ) to the manifold.

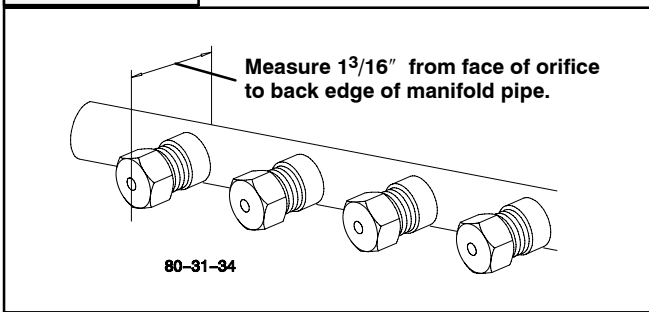
**Figure 4****Manifold/Orifice Measurement**

### Changing Pilot Burner Orifice (Required for Converting from Propane Gas to Natural Gas) (All models except PGF3, PGX3, and PDX3).

1. Disconnect the pilot supply line from the pilot burner.
2. Remove pilot orifice from pilot burner. Replace with natural gas orifice stamped which is provided in kits (**Figure 5**)
3. Reconnect the pilot tubing securely to the pilot burner.
4. Verify proper relationship of pilot burner assembly **per figure 6**, prior to completing the conversion.

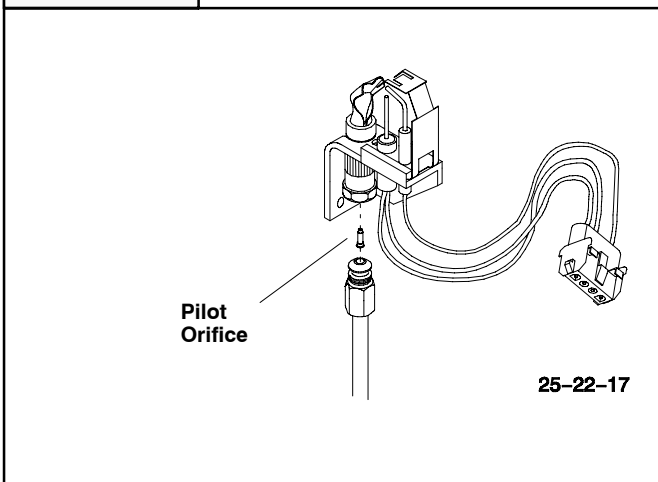
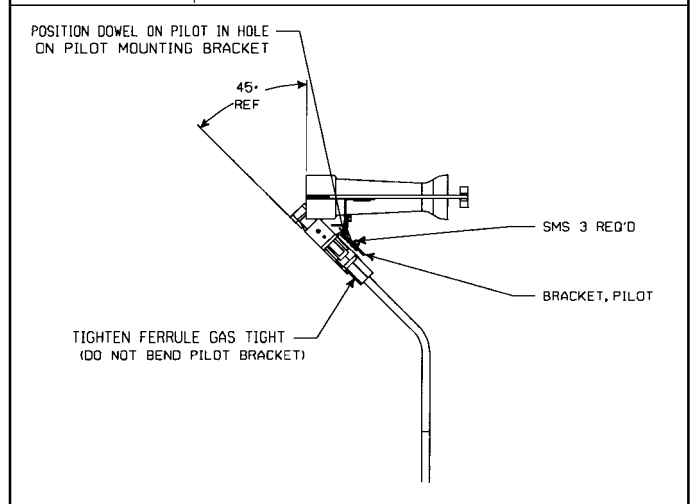
**Figure 5****Changing Pilot Orifice****Figure 6****Burner Pilot Assembly**

### Gas Valve Conversion (Required for Converting from Propane Gas to Natural Gas)

Conversion of Honeywell VR8200, SV9500, SV9501 and VR8204M Gas Valves using Natural Gas Conversion Kit # 396222.

1. Remove the regulator cap screw and pressure regulator adjusting screw. (See **Figure 10**)
2. Remove the existing regulator spring from the regulator housing.
3. Insert the replacement spring (stainless steel) contained in this kit into regulator housing.

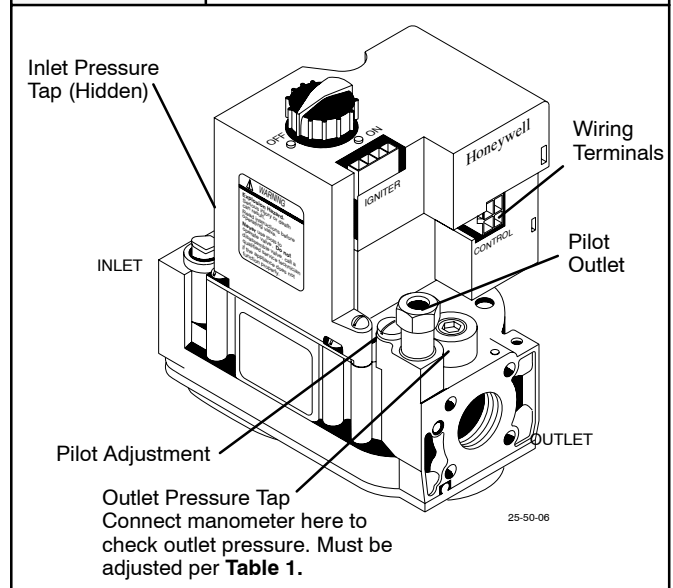
**Figure 7****Typical Gas Valve Honeywell SV9500**

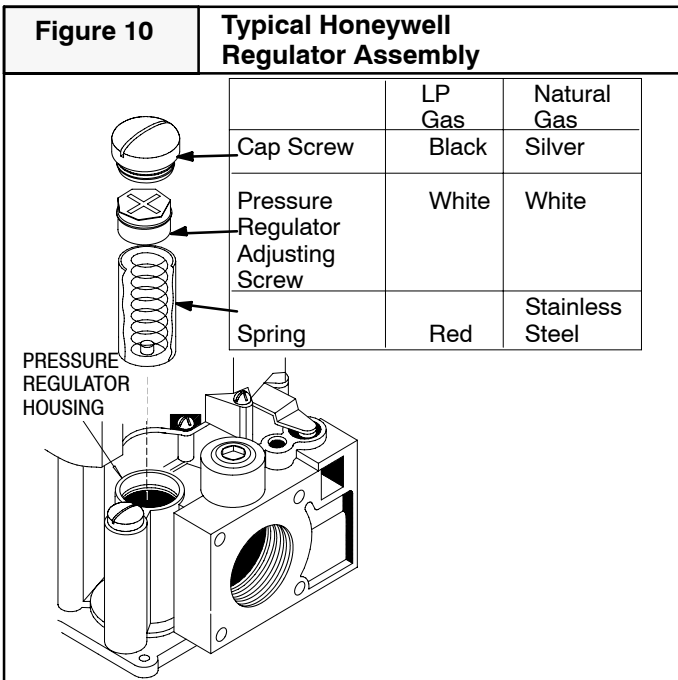
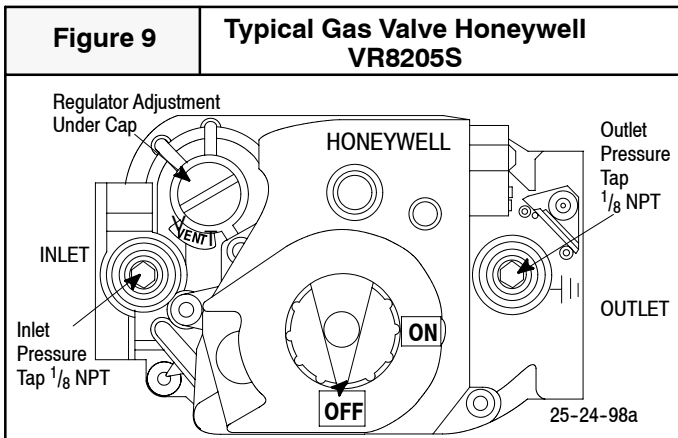
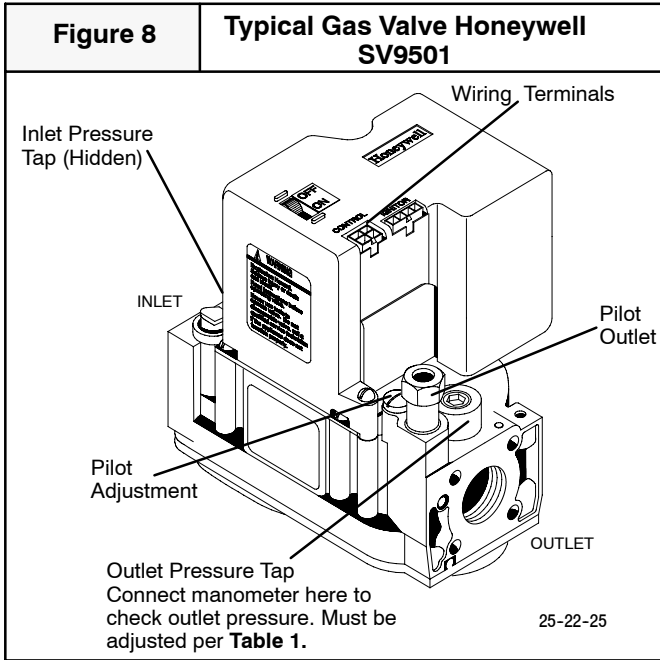

4. Install the pressure regulator adjusting screw. This will set the manifold pressure close to required setting for normal operation.
5. Replace the regulator cap screw.
6. Attach gas valve conversion label (found in Honeywell conversion kit) to gas valve.

## Reassembly

Reassemble all parts in reverse order as removed. Attach Natural Gas Conversion Label next to the unit rating plate. Fill out and attach the Field conversion Label to the front exterior of the furnace.

- **Manifold Assembly** - Be sure to engage the main burner orifices in the proper openings in the burners.
- **Testing for leaks** - After reassembly, turn the gas on and check all joints for gas leaks using a soapy solution. All leaks must be repaired immediately.

## Start-up and Check-out

1. Remove the plug from the Inlet Pressure Tap on gas valve and install a manometer. (See **Figures 7, 8, 9, & 10**)
2. Open manual gas line valve to unit. Check for gas leaks and correct as necessary. Check supply pressure. Refer to **Table 2** for proper supply pressure values. If not within these limitations DO NOT OPERATE UNIT, contact gas supplier.
3. Close manual gas line valve to unit, remove manometer and replace inlet pressure tap plug.

## Gas Valve Adjustment

4. With the gas valve knob in the OFF position, remove the pressure tap plug from the outlet end of the valve, and connect a "U" tube manometer to the pressure port. (See **Figure 7, 8, 9 & 10**).
5. Turn the gas valve knob to the ON position and restore electrical power to unit. Cycle the main burner on and off several times to stabilize the pressure regulator diaphragm. This MUST be done before an accurate pressure reading can be obtained.
6. With the main burner on, read the pressure gauge. Manifold pressure should be adjusted to values from **Table 2**. Turn pressure regulator adjusting screw clockwise to increase or counterclockwise to decrease manifold pressure. Burner Input must not exceed nameplate rating. **Refer to Section "Checking Input Rate"**.
7. Turn gas valve to OFF. Remove the pressure gauge and replace the pressure tap plug and pressure regulator cap screw.
8. With gas valve on, observe furnace through two or more complete cycles to be sure all controls are operating.

# ⚠ WARNING

## FIRE AND/OR EXPLOSION HAZARD

Failure to follow this warning could result in personal injury, death, and/or property damage.

Do NOT attempt to light the burner with a match or flame of any kind.

## HEATING INPUT RATE CHECK

The gas input to the unit is determined by measuring the gas flow at the meter. Measuring gas flow at the meter is recommended for natural gas units. To measure the heating input, perform the following steps:

1. Turn off all other gas appliances that use the same meter.
2. Turn off gas supply to unit and attach manifold pressure gauge as instructed in the "Gas Valve Adjustment" section.
3. With gas **ON** to the unit and the unit operating, record the number of seconds for the gas meter dial to make one revolution.

4. Divide number of seconds in Step 3 into 3600 (number of seconds in 1 hour).
5. Multiply result of Step 4 by the number of cubic feet shown for one revolution of the meter dial to obtain the cubic feet of gas flow per hour.
6. Multiply result of Step 5 by Btu heating value of gas to obtain total measured input in Btu/hr. Compare this input rate with the Required Input Rate for the installation altitude, as shown in **Table 3**. Consult with local gas supplier if the heating value of gas is not known.

Example: Assume that the size of the meter dial is 1 cu. ft., one revolution takes 44 seconds, and the heating value of the gas is 1020 Btu/ft<sup>3</sup>. Proceed as follows:

1. 38 sec. To complete 1 revolution
2.  $3600/38 = 94.7$
3.  $94.7 \times 1 = 94.7$
4.  $94.7 \times 1020 = 96,632$  Btu/hr

For this example, the nameplate input is 100,000 Btu/hr, so only a minor change in manifold pressure is required. In no case should the final manifold pressure vary more than  $\pm .3$  "water column from the values in **Table 2**. Never exceed the required input rate (**Table 3**).

**Table 3**

Required Input Rate for All Models									
Heating Model Size <sup>1</sup>	Required Input Rate of Furnace Converted to Natural Gas (Btu/hr)								
	Elevation Above Sea Level (feet)								
	0-2000	2001-3000	3001-4000	4001-5000	5001-6000	6001-7000	7001-8000	8001-9000	9001-10000
"040" or "B"	40,000	35200	33600	32000	30400	28800	27200	25600	24000
"060" or "C"	60,000	52800	50400	48000	45600	43200	40800	38400	36000
"080" or "D"	80,000	70400	67200	64000	60800	57600	54400	51200	48000
"100" or "E"	100,000	88000	84000	80000	76000	72000	68000	64000	60000
"120" or "F"	120,000	105600	100800	96000	91200	86400	81600	76800	72000
"140" or "G"	140,000	123200	117600	112000	106400	100800	95200	89600	84000

<sup>1</sup>Note:

For PGF3, PGX3, and PDX3 models, heating model size is indicated by the numbers in the 5<sup>th</sup>, 6<sup>th</sup>, and 7<sup>th</sup> characters in the model number.

For PGF, PGC, PGS models, heating model size is indicated by the numbers in the 8<sup>th</sup>, 9<sup>th</sup>, and 10<sup>th</sup> characters in the model number.

For GPFM, GPCM, and GPSM models, heating model size is indicated by the numbers in the 8<sup>th</sup>, 9<sup>th</sup>, and 10<sup>th</sup> characters in the model number.

For PGAA, PGAD, PGCA, and PGCD models, heating model size is indicated by the letter in the 7<sup>th</sup> character in the model number.

For PGMD and PGME models, heating model size is indicated by the letter in the 7<sup>th</sup> character in the model number.

## Pilot Burner Flame Check (All models except PGF3, PGX3, and PDX3)

Adjust flames so they surround  $\frac{3}{8}$ " (9 mm) to  $\frac{1}{2}$ " (13 mm) of the sensor tip (See **Figure 11**).

1. Remove the cap from the pilot adjusting screw (See **Figures 7 & 8**).
2. Turn pilot adjusting screw counterclockwise to increase, clockwise to decrease.
3. Replace the cap on the pilot adjusting screw.

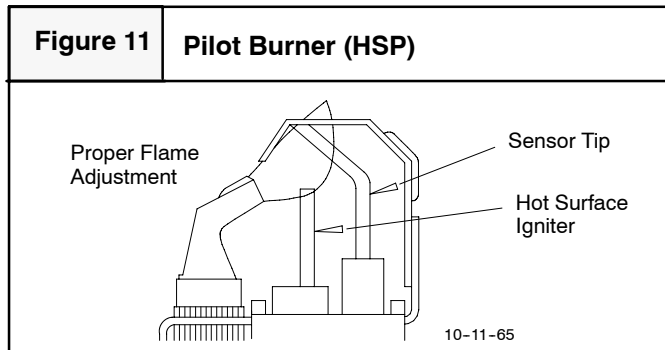

## Main Burner Flame Check

Check for the following:

- Stable and blue flames (See **Figure 12**). Dust may cause orange tips or wisps of yellow, but flames **MUST NOT** have solid, yellow tips.
- Flames extending directly from burner into heat exchanger.
- Flames **DO NOT** touch sides of heat exchanger

